

Semi-Automatic Cartoning Machine

The **Model M-300** intermittent vertical cartoner automatically opens/folds cartons for manual insertion of a container, then automatically closes the bottom flap. The **M-300** can handle a wide range of cartons, containers, bottles, blister packs, pouches, sachets or tubes.

Features and Benefits

- Small footprint is ideal for space sensitive operations
- User friendly design requires only one operator
- Tooling change-over can be completed in 20 minutes or less
- Simplified engineering design allows for ease of maintenance
- Constructed with materials that meet GMP
- Safety guarding
- Speed regulation by means of a inverter
- Using vacuum pump to accurate open carton
- High precision Index provide of accurate intermittent operation station
- Torque limiter-preventing starwheel from colliding

Options

- Hot stamp imprinter for coding expiration date or series number on the box
- Hot-melt glue sealing cartoning M/C (Model M-300H) is available
- Modification for automatic infeed system

Specifications

Capacity	Max 60 cartons/min
Compressed Air	5kg/cm ²
Consumption	5L/min
Power Supply	AC 220V 60/50Hz Single Phase
Power Consumption	0.6kw
Weight	350kgs
Packing Size (cm)	150 (L) x 140 (W) x 135 (H)



Working Area (Top view)

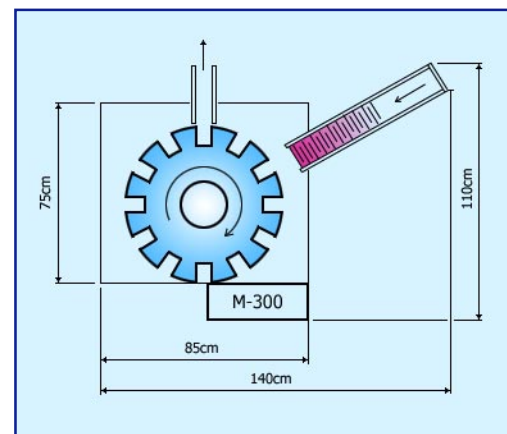

M/C Size (cm): 140 (L) x 110 (W) x 115 (H)

Carton Size

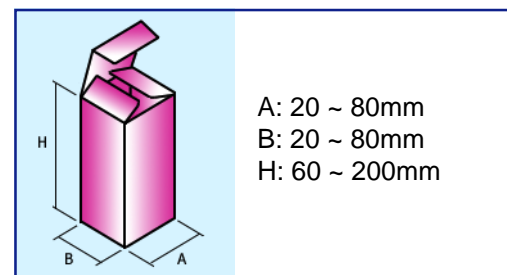

Note: Special format size on request